

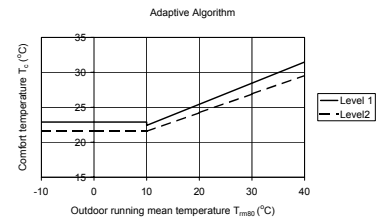

Project n°  
TREN/04/FP6EN/SO7.31838/503183

Acronym : SARA

Title : Sustainable Architecture Applied to  
Replicable Public-Access Buildings



Instrument : Integrated project

Thematic Priority : [6.1.3.2.1] [ECO-BUILDINGS]

## D21: Adaptive Control Algorithm

Due date of deliverable:

30/11/2005

Actual submission date:

23/12/2005

Start date of project :

1st June 2004

Duration:

4 years

Organisation name of lead contractor for this deliverable:

Oxford Brookes University

Revision:

[V 1]

Project co-funded by the European Commission within the Sixth Framework Programme (2002-2006)		
Dissemination Level		
PU	Public	X
PP	Restricted to other programme participants (including the Commission Services)	
RE	Restricted to a group specified by the consortium (including the Commission Services)	
CO	Confidential, only for members of the consortium (including the Commission Services)	

**INDEX**

<b>1</b>	<b>STATE OF THE ART REVIEW .....</b>	<b>3</b>
<b>2</b>	<b>DEVELOPING THE ADAPTIVE ALGORITHM .....</b>	<b>3</b>
<b>2.1</b>	<b>Defining and calculating the comfort temperature .....</b>	<b>4</b>
<b>2.2</b>	<b>Thermal Comfort Surveys-SCAT project .....</b>	<b>5</b>
<b>2.3</b>	<b>Deriving the shape of the adaptive algorithm .....</b>	<b>7</b>
<b>2.4</b>	<b>The adaptive algorithm .....</b>	<b>7</b>
<b>2.5</b>	<b>Comfort temperature .....</b>	<b>8</b>
<b>2.6</b>	<b>References.....</b>	<b>9</b>
<b>3</b>	<b>DEVELOPING CONTROLS .....</b>	<b>9</b>
<b>3.1</b>	<b>The control algorithm.....</b>	<b>10</b>
<b>4</b>	<b>IMPLEMENTING THE CONTROL ALGORITHM IN SARA .....</b>	<b>11</b>

## 1 STATE OF THE ART REVIEW

The International Standard for indoor temperatures favours the provision of constant temperatures in buildings. This follows from the way in which such standards are based on steady-state experiments in climate chambers and the necessity to specify clothing and metabolic rates of building occupants in order to predict the effects of the environment. However there is an increasing realisation that such methods may be inappropriate and restrictive, particularly for variable conditions such as may be found in naturally ventilated (NV) buildings. Research analysing field work throughout the world has shown that the temperature which people find comfortable varies with season and climate.

Recent work has suggested that the comfort temperature indoors can be defined by a time-series of the outdoor temperature. This means that comfort can be achieved using less energy because the indoor temperature follows that outdoors. It also means that well designed buildings can fall within the range of temperatures which are comfortable without the use of air conditioning.

The work to be developed in this task is based on an algorithm for the prediction of comfort temperatures in buildings using the outdoor temperature. This algorithm has been tested for UK conditions using dynamic thermal simulations and was also tested in actual buildings. The use of such an algorithm can be shown to produce energy savings of up to 25% when it is used to define the set temperature in air conditioned and partially mechanically ventilated buildings. In the warmer conditions of Southern Europe even greater savings might be expected.

The comfort algorithm includes the following parts

- A definition of the indoor temperature which is to be controlled in terms of the globe temperature and the air velocity
- A formula relating the desired value of the indoor temperature to the exponentially weighted running mean of the outdoor temperature.

The purpose of the proposed work is

- to implement this control algorithm
- to develop control systems which respond to the control algorithm
- to test the innovative control systems in real buildings to confirm the potential for energy saving and to confirm that occupant comfort is not compromised.

The algorithm will require a calculation of the running mean of the outdoor temperature. The required indoor temperature is then calculated from the daily mean and the running mean of the outdoor temperature. In air conditioned (AC) buildings this is used as the set-point temperature. In NV buildings the same input information will be used to assess whether the building is likely to provide indoor comfort. This means that it is more dependent on the exact nature of the building and the controls over indoor conditions which it affords.

## 2 DEVELOPING THE ADAPTIVE ALGORITHM

Using statistical techniques on the results of the comfort surveys an appropriate algorithm will be developed. The result is an adaptive algorithm which is the basis for the development of the adaptive controls.

This algorithm can then be used to define comfortable indoor conditions and can be used to control air conditioning systems or assess whether naturally ventilated buildings will provide comfortable indoor temperatures.

## 2.1 Defining and calculating the comfort temperature

The comfort can variously be described as

- The temperature at which an average subject will be comfortable (or neutral) on the comfort scale or
- The temperature at which the greatest number of subjects will be comfortable.

In field surveys the normal method for predicting the comfort temperature as defined by 1) is the use of regression analysis. A method which has often been used to predict the comfort temperature as defined by 2) is probit analysis.

Each of these methods assumes that the comfort temperature is a constant – at least during the time of the survey.

The present work is based on the assumption that the comfort temperature is changing with time in a way which is related to the outdoor temperature. This means that the comfort temperature is constantly changing, possibly from day to day, certainly from week to week [1]. So instead of there being a constant comfort temperature, it is in a constant state of change. A body of data, unless it is collected within a very short time-frame, or under very constant conditions, will not have a single comfort temperature.

There are also some problems with the use of regression analysis where there are various forms of errors in the predictive (in this case physical) variables. These may be measurement errors or errors associated with the applicability of the measurements taken. Humphreys and Nicol [2] have looked at this problem and suggested that the use of an *assumed* regression slope for the relationship between comfort vote and temperature (or environmental index) following the example of Griffiths [1] will improve predictive accuracy. For the present analysis it also has the advantage that predictions of comfort temperature can be made from small bodies of data and can therefore predict an instantaneous comfort temperature as it changes with time.

After inspection of the ASHRAE database of thermal comfort [3] Humphreys and Nicol suggest that an appropriate slope for the relationship at 0.5. This suggests that the comfort temperature ( $T_c$ ) can be calculated from the value of the globe temperature ( $T_g$ ) and the thermal comfort vote (TF) using the equations:

$$TF = 0.5 T_g + C \quad (1)$$

which at the comfort temperature (see definition 1) of comfort temperature above) becomes:

$$4 = 0.5 T_c + C \quad (2)$$

solving to remove the unknown constant C gives an instantaneous comfort temperature

$$T_c = T_g - 2(TF - 4) \quad (3)$$

The globe temperature is used as an approximation to the operative temperature.

One problem for the adaptive approach to thermal comfort, which relates the comfort temperature inside buildings to the outdoor temperature is to characterise the *rate* at which the comfort temperature changes. This has been a concern of much work in this area [4]. A

common measure of outdoor temperature used as a predictor for indoor comfort temperature is the exponentially-weighted running mean of the daily mean outdoor temperature. The series is defined as:-

$$T_{rm} = (1-\alpha) \cdot \{T_{od-1} + \alpha \cdot T_{od-2} + \alpha^2 T_{od-3} \dots\} \quad (4)$$

Where  $T_{rm}$  is the running mean temperature and  $T_{od}$  is the daily mean outdoor temperature (when  $T_{rm}$  is the running mean temperature for a particular day,  $T_{od-1}$  is the daily mean outdoor temperature for the previous day and so on).  $\alpha$  is a constant between 0 and 1 which defines the speed at which the running mean responds to the outdoor temperature and the characteristic time period of the relationship.

The way in which the running mean temperature changes is equivalent to the decay of a radioactive source with a characteristic half-life. The half-life of a particular running mean is approximately  $0.69/(1-\alpha)$  days, so that the greater the value of  $\alpha$  the longer the half-life. In this study the daily mean is used as the basic temperature unit, though any period (a minute, an hour, a week) could in theory be used. This is partly through convenience – the daily mean temperature is easily obtained - and partly that the day is the basic unit of most people's lives, for instance in the choice of clothing.

The use of an infinite series would be very time consuming except that equation (4) can easily be reduced to

$$T_{rm}^n = (1-\alpha) \cdot T_{od}^{n-1} + \alpha \cdot T_{rm}^{n-1} \quad (5)$$

Where  $T_{rm}^n$  is the running mean temperature for day n and so on. This means that once the running mean has been calculated (or approximated) for one day, then it can be calculated for the next day and all following days from this value and the daily mean outdoor temperature.

The values of  $T_{rm}^n$  and  $\alpha$  can be determined by using statistical analysis.

## 2.2 Thermal Comfort Surveys-SCAT project

During the course of the SCATs project, thermal comfort data was collected from a number of buildings throughout Europe. 25 buildings were surveyed across the UK, France, Sweden, Greece and Portugal by members of the SCATs consortium. This data formed 3 distinct databases of thermal comfort (transverse, longitudinal and background data) which has potential for further R&D.

The data collected included indoor and outdoor temperatures, thermal comfort responses, occupant use of controls, demographic data of building occupants, clothing insulation and metabolic rate.

Three databases are available: transverse data, longitudinal data and background data.

### *Transverse Data (Level 1)*

Approximately 5000 responses are available for analysis. The database shows building number, gender, occupant code, date, time, comfort vote and preference vote for 5 environmental criteria (temperature, air movement, humidity, lighting, noise), clothing

insulation (CLO), activity level (metabolic rate), sound level (dB), lighting level (lux), air velocity (ms<sup>-1</sup>), air temperature (oC), mean radiant temperature (oC), relative humidity (%), CO<sub>2</sub> level (ppm), rating of productivity, rating of indoor air quality, outdoor temperature and relative humidity (some records), use of controls (eg. door, windows, blinds, etc.).

The following subjective responses were polled from the subjects:

- Temperature - comfort vote (7 point scale) and preference (5 point scale)
- Air movement - comfort vote (7 point scale) and preference (5 point scale)
- Humidity -comfort vote (7 point scale) and preference (5 point scale)
- Lighting - comfort vote (7 point scale) and preference (5 point scale)
- Noise - comfort vote (7 point scale) and preference (5 point scale)
- Air quality vote (7 point scale)
- Overall comfort (6 point scale)
- Perceived productivity (5 point scale)

Details were also collected of

- Clothing worn (a record was made of each item being worn, normal underclothing was assumed in order to avoid causing offence). The clo value of the full assembly of garments worn was calculated from standard tables, inclusive of the chair on which the subject was seated where appropriate.
- Activity over the last hour. Where more than one activity had been undertaken this meant dividing the hour into five minute periods and assessing the period of time for each activity. The weighted mean metabolic rate was calculated for all the activities reported.

Use being made of controls – doors, heating/air conditioning, windows, blinds, lights, fans - at the time of the survey

#### *Longitudinal Data (Level 2)*

Approximately 25000 responses are available for analysis. The database shows building number, gender, occupant code, date, time, thermal comfort and preference vote, clothing insulation (CLO), activity level (metabolic rate), globe temperature (oC), relative humidity (% - some records), outdoor temperature and relative humidity (some records), use of controls.

In the Level 2 survey a number of copies of the questionnaire were left with the subject, who then filled them in up to four times a day subject to availability. The subjects filled the questionnaire simply as a check-list with ticks. The subjective questions were limited to the thermal environment, there was an abbreviated version of the clothing descriptions and the activity. Use of controls was also recorded. The temperature (and in some cases the relative humidity) close to the subject was recorded by a miniature datalogger.

#### *Background Data*

In addition to the Transverse and Longitudinal surveys a background survey was conducted in each of the buildings in which all the Level 1 subjects were asked to fill in a questionnaire. This dealt with the attitude of the subjects to the building, its controls and speed of reaction, their judgement of what was important and other details of such things as their health and so on.

Approximately 400 records of background data on building occupants, relating to information above. Records include demographic data, details of job, general views on environmental conditions, views on other aspects of building (e.g. layout, cleanliness, etc.), use of controls and occupant health.

## 2.3 Deriving the shape of the adaptive algorithm

The data in the SCATS database is well suited to informing the choice of an appropriate value for  $\alpha$  in the running mean equation: The Level 1 surveys, because they are spread over a year give the possibility of deciding, through correlation analysis, which is the optimal value of  $\alpha$  for prediction of the comfort temperature. The Level 2 surveys were undertaken on a continuous longitudinal basis with the time factor in mind. In theory they will be better for this task, though the poorer quality of the data may work against this. Both databases have been used for this analysis.

The best value for  $\alpha$  is not immediately obvious. It may well be that the actual time delay has a number of characteristic time periods. It has been found [5] in the analysis that the best time period varies from building to building and from country to country. This instability is the effect one would expect if a number of processes (say changing clothes, adjusting posture and opening windows) which have different time characteristics and are used in different proportions according to (say) dress code, furniture or access to windows. A value of 0.8 for  $\alpha$  has been accepted [5]. Further confirmation of this is given below.

A value of 0.8 for  $\alpha$  gives half life of  $0.69/0.2$  or about  $3\frac{1}{2}$  days, suggesting that the characteristic time subjects take to react to a change in outdoor weather is about half a week. The value of  $T_c$  has been plotted against the running mean outdoor temperature for  $\alpha = 0.8$ . The result is given in Figure 1 below. The Lowess regression line is given. It will be seen that an approximately constant value of  $T_c$  is predicted for  $T_{rm}$  less than  $10^\circ\text{C}$ . With  $T_{rm} > 10$  the comfort temperature follows an approximately linear relationship with outdoor temperature and a slope of about 0.3. It should be noted that a similar form of curve results when other measures of outdoor temperature (e.g.  $T_{od}$ ) are used.

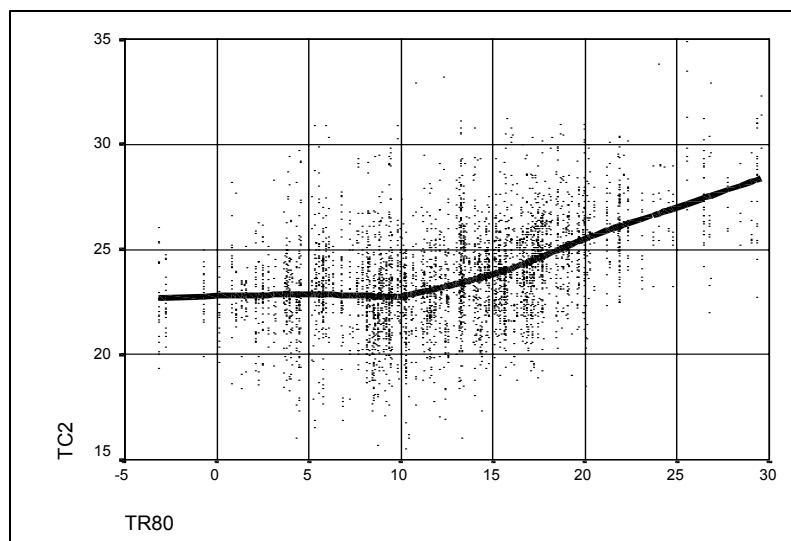

Figure 1. Change of comfort temperature ( $TC_2$ ) with running mean temperature ( $TR_{80}$ ) (data from Level 1 survey - a similar relationship is found with the level2 survey, though Lowess analysis cannot be used because of restrictions in the number of cases in SPSS)

The implication of the curve in Figure is that the comfort temperature can be taken as a constant if the running mean of the daily mean outdoor temperature is below  $10^\circ\text{C}$ . By dividing the data between those responses for which  $T_{rm}$  is above  $10^\circ\text{C}$  from those where it is above we can evaluate what the best relationship will be best for the algorithm.

## 2.4 The adaptive algorithm

Taking account of all the considerations above the suggested adaptive algorithm is:

- 1) from the Level 1 survey

when  $T_{rm80} < 10^{\circ}\text{C}$ ,  $T_c = 22.9^{\circ}\text{C}$

when  $T_{rm80} > 10^{\circ}\text{C}$ ,  $T_c = 0.302 * T_{rm80} + 19.4$

2) from the Level 2 survey

when  $T_{rm80} < 10^{\circ}\text{C}$ ,  $T_c = 21.6^{\circ}\text{C}$

when  $T_{rm80} > 10^{\circ}\text{C}$ ,  $T_c = 0.267 * T_{rm80} + 18.9$

These two equations are plotted in Figure 2. The two surveys give somewhat different recommended temperatures. In this regard the Level 1 results are probably more applicable, since the measurements made in the level 1 surveys were more accurate.

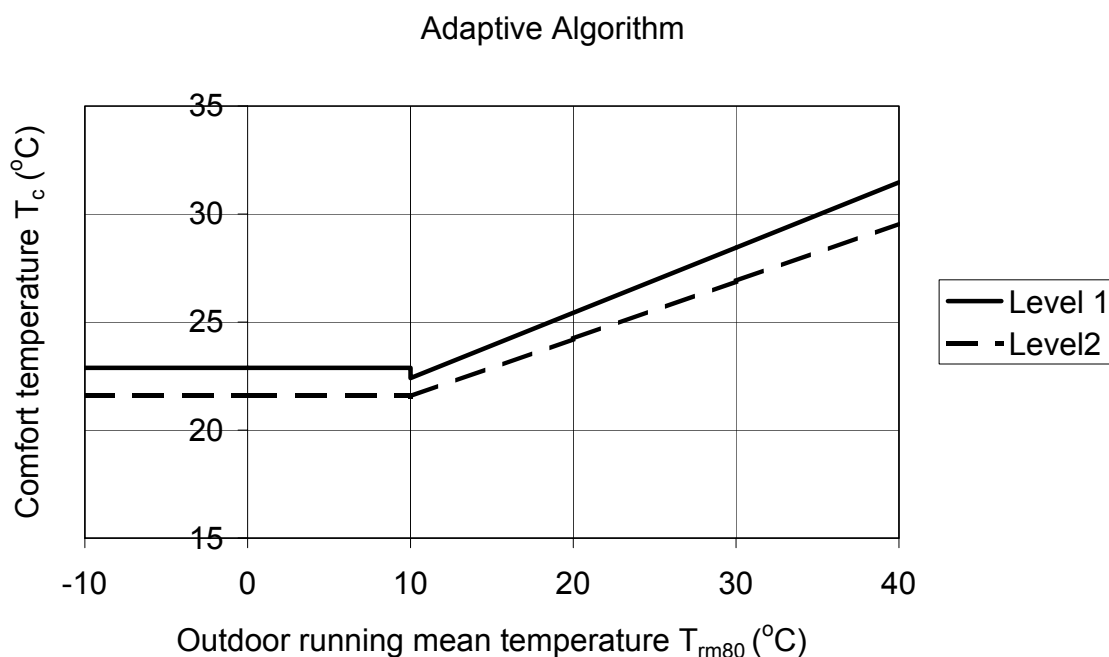

Figure 2. Values of the recommended indoor temperature as a function of the running mean outdoor temperature  $T_{rm80}$

## 2.5 Comfort temperature

The general shape of the comfort equation seems to be quite robust (i.e. little change of  $T_c$  with outdoor temperature when outside temperature is below 10, general increase thereafter). Table 1 gives the equations for each survey dividing between results when  $T_{rm80}$  is above and below  $10^{\circ}\text{C}$ .

Table 1 Algorithms

	Level 1		Level 2	
	$T_{r80} < 10$	$T_{r80} > 10$	$T_{r80} < 10$	$T_{r80} > 10$
UK	$0.104T + 22.58$	$0.168T + 21.63$	$0.047T + 21.10$	$0.188T + 19.55$

The level 1 surveys give a higher comfort temperature than those from the level 2 surveys by a degree or two.

## 2.6 References

- [1] Nicol F and Raja I: (1996) Thermal comfort, time and posture: exploratory studies in the nature of adaptive thermal comfort, School of Architecture, Oxford Brookes University. March 1996
- [2] Humphreys M.A. and Nicol J F (2000) The effects of measurement and formulation error on thermal comfort indices in the ASHRAE database of field studies *ASHRAE Transactions 2000* **206(2)**
- [3] Griffiths, I. (1990) *Thermal comfort studies in buildings with passive solar features; field studies* Report to the Commission of the European Community, ENS35 090 UK (1990)
- [4] de Dear, R. & Brager, G. (1998) Developing and adaptive model of thermal comfort and preference. *ASHRAE Transactions 104 (1)* (in press). Also available in ASHRAE Technical Data Bulletin Vol. 14 (1) *Field studies of thermal comfort and adaptation* (Ed Geschwiler M et al) American Society of Heating Refrigeration and Air-Conditioning Engineers
- [5] see e.g. Humphreys, M. A. (1973) Clothing and comfort of secondary school children in summertime. *Thermal comfort and moderate heat stress, proceedings of CIB commission W45 (Human Requirements)*. HMSO
- Humphreys, M. A. and Nicol, J. F. (1995) An adaptive guideline for UK office temperatures. in *Standards for thermal comfort: indoor air temperature standards for the 21st century*. (Ed. Nicol JF, Humphreys MA, Sykes O and Roaf S) London, E & FN Spon
- Nicol, J. F. and Raja, I. A. (1996) *Thermal comfort, time and posture: exploratory studies in the nature of adaptive thermal comfort*, (Report) School of Architecture, Oxford Brookes University
- Nicol J F (2000) Time and thermal comfort, evidence from the field in *Renewables: the energy for the 21<sup>st</sup> century WREC VI, Brighton, part 1* pp477-482, Pergamon Press, Oxford, ISBN 0 080 43865

## 3 DEVELOPING CONTROLS

Based on the above well known results, control units for the appropriate level(s) will be adapted to include the new algorithms.

The task of developing the controls can be divided in two parts. The first is the implementation of the algorithms. The second is the development of means for occupant feedback which should influence the control.

For the first part an application specialist has been assigned who will implement the algorithms once they have been agreed and handed over. It is necessary to make additions to existing software for application in programming existing controllers.

For the work of the second part the key ideas are the following:

- The goal is to obtain occupant feedback on how the working environment (temperature, draught, light, humidity, noise, etc.) is perceived
- It should be simple to fill out.
- The occupant is required to answer the questions before continuing the interrupted work (this may be optional at a later stage).

### 3.1 The control algorithm

The control algorithm is used to calculate the comfort temperature setpoint depending on the historical outdoor temperature in a very specific way explained below.

The comfort temperature setpoint is then used to control the indoor temperature.

What has to be implemented at BMS level is the following:

1. The actual outdoor temperature is measured once every hour, added up, and the average outdoor temperature is calculated once every day at 7 o'clock (no adjustment for daylight saving time).
2. The Running mean temperature is calculated as:

$$T_{RM} = \text{Running mean temperature}$$

$$T_{DM} = \text{Actual average temperature}$$

$$T_{RM}^n = c * T_{DM}^{n-1} + (1-c) * T_{RM}^{n-1}$$

where the constant  $c$  is set default to 0.2.

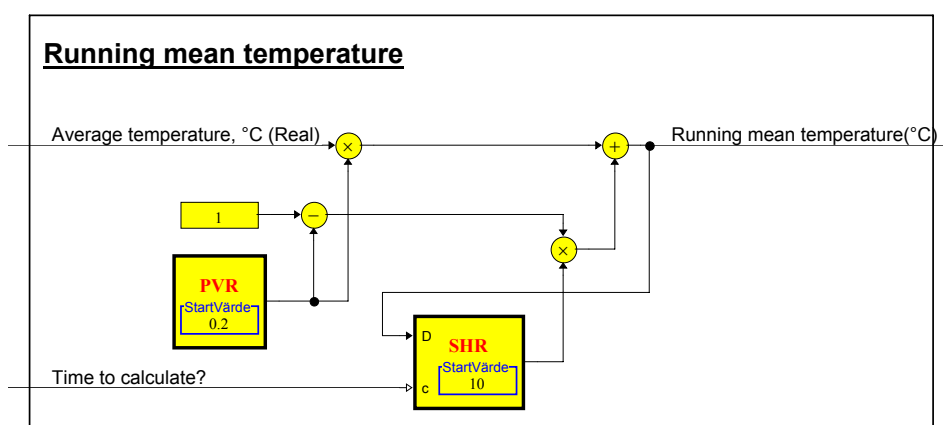

#### Running mean temperature calculation

3. The Control temperature is calculated as

If the running mean temperature is below 10 °C, the Control temperature is set to a fixed value of 22.88 °C.

In other cases, the Control temperature is calculated as:

$$T_c = a * T_{RM} + b \text{ where}$$

$$a = 0.302$$

$$b = 19.39$$

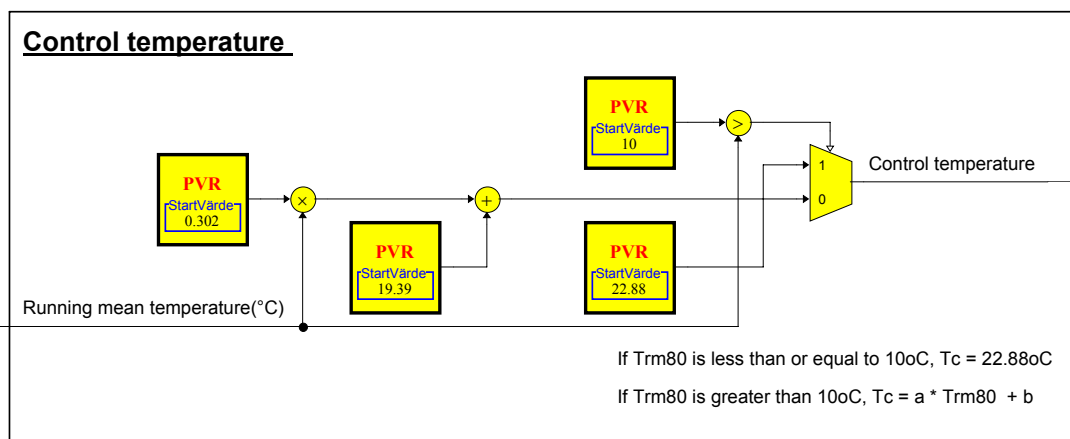

**Control temperature calculation**

#### 4 IMPLEMENTING THE CONTROL ALGORITHM IN SARA

As part as the Sara project implementation, the control algorithm will be implemented in the Southampton building.

To this end, meetings were held with the building manager and with engineers from the company that provides the BMS system. The main agreement between SARA project and the University states that

1. The University agreed that there was no objection in principal to the adoption of the algorithm but that there were contractual problem in the new building as the software is contracted and there is a 12 month warranty period.
2. It was agreed that it would therefore be interesting to try the algorithm in the adjacent/older part of the building during the next 12 months and then to do the same in the new part of the building once the 12 month warranty period expires.
3. OBU will start to collaborate directly with TREND (BMS providers) and with the building manager to set up the algorithm.

The aim is to have the control algorithm implemented in the BMS system bu June 2006.

<sup>i</sup> Griffiths, I. (1990) *Thermal comfort studies in buildings with passive solar features; field studies* Report to the Commission of the European Community, ENS35 090 UK (1990)